



<p>Team Name: Environmental Services</p> <p>Team Lead: Regional Manager Environmental Services</p> <p>Approved by: Executive Director - Acute & Chief Nursing Officer</p>	<p>Reference Number: ORG.1910.PR.010</p> <p>Program Area: Support Services</p> <p>Policy Section: Housekeeping</p>
<p>Issue Date: January 29, 2020</p> <p>Review Date:</p> <p>Revision Date:</p>	<p>Subject: Wet Mopping Floors / Microfiber Mopping System</p>

Use of pre-printed documents: Users are to refer to the electronic version of this document located on the Southern Health-Santé Sud Health Provider Site to ensure the most current document is consulted.

PROCEDURE SUBJECT:

Wet Mopping Floors / Microfiber Mopping System

PURPOSE:

- To provide a clean environment for client/resident.
- To enhance the visual appearance of the environment.
- To prevent infections through cross contamination.

PROCEDURE:

1. Use appropriate Personal Protective Equipment (PPE) according to Safety Data Sheet (SDS). Prepare fresh cleaning solution for the charging bucket according to the manufacturer’s instructions. Fill to the 3 quart fluid level line, which is enough solution to saturate 15 mop pads.
2. Place mop pads on their side in bucket and let sit for 5 minutes. Then flip mop pads onto the other side for 5 minutes. Then place mop pads side down.
3. Ensure the floor has been dry mopped. See procedure Dry Mopping Floors (ORG.1910.PR.008).
4. Place ‘wet floor’ sign in the entrance way where it is visible to clients/residents, visitors and staff. Do not obstruct entrance way.
5. Center the mop handle and frame over the loaded charging bucket, then push downward to attach the mop pad to the frame.
6. Wash the floor by pushing the mop around the baseboard to the farthest part of the room, pay attention to remove soil from the corners.
Use overlapping figure eight strokes while moving backward toward the door.
Remember to mop beneath beds and furniture and behind doors.

7. Change mop pad when you are finished mopping the room, or when the pad is heavily soiled or too dry. Single rooms will require two mop pads, one for the room and one for the washroom. Mop pads used in the washroom should never be used in the client's room.
8. Remove the pad from the frame by placing one foot on the exposed edge of the mop pad, and the other on the frame. Pull the handle upward and the mop pad will peel away from the frame. Lift the soiled mop pad using the frame, positioned at 90° angle to the pad. The mop pad ends now fold downward and can be easily pulled from the frame and deposited into the appropriate container. Bigger rooms or very soiled rooms may require more than one mop pad. (see diagram).
9. Deposit soiled mop pad in appropriate area.
10. Clean equipment.

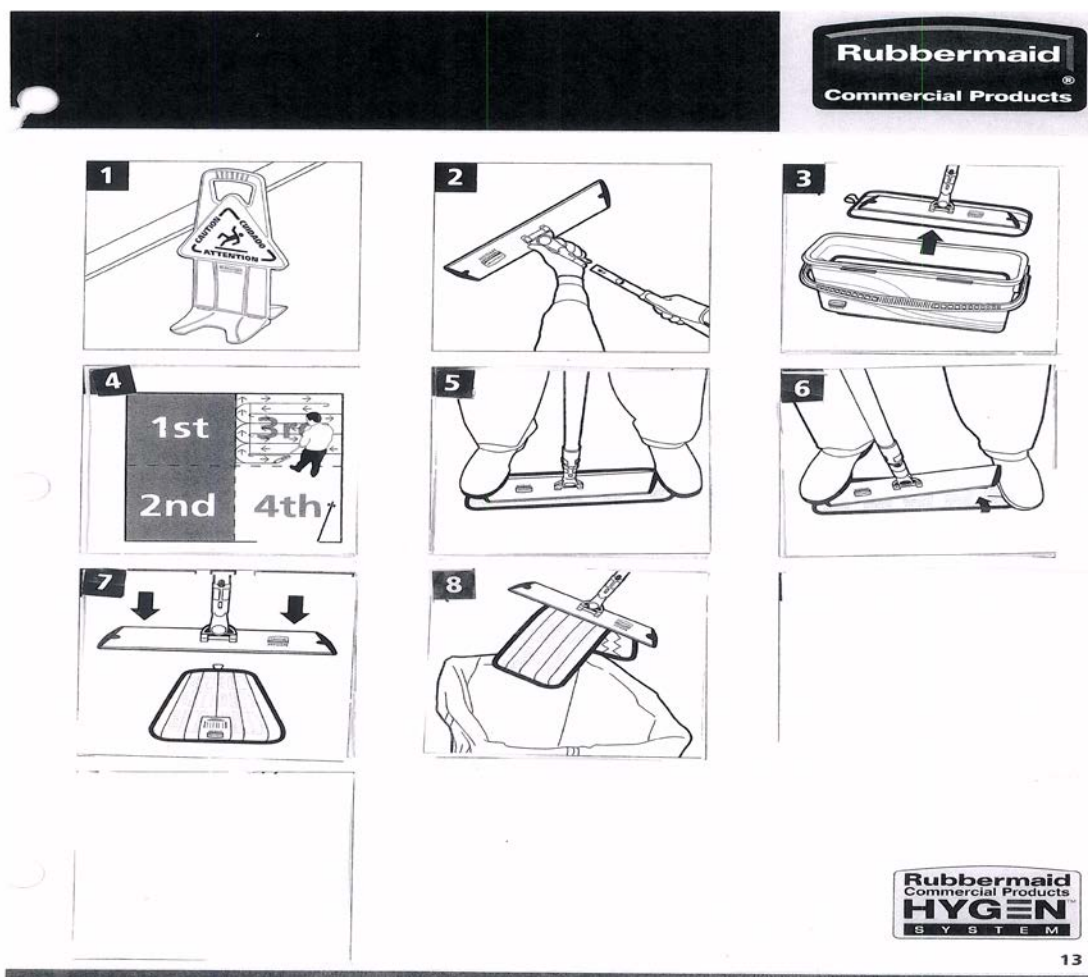

REFERENCE:

[ORG.1910.PR.008](#) Dry Mopping Floors